



## Installation Guide

### Mercedes Benz

---

IR-MBZ42  
IR-MBZ42-CTR  
IR-MBZ4INT  
IR-MBZ4INT-CTR  
MBZSUB82-1L  
MBZSUB82-2L

## **Dear Customer,**

Thank you for choosing Morel for your car audio speaker solution.

Morel prides itself on engineering and producing the best high-fidelity speaker systems.

We hope you enjoy your Integration Reference speakers for years to come.

If you have any questions, please contact your Morel dealer or Morel support at:

[www.morelhifi.com](http://www.morelhifi.com)

# Components

## Component System

---



x2  
Midwoofer



x2  
Tweeter



x2  
Midwoofer  
Connecting Cable



x2  
Cable Splitter



x2  
MBZ002  
(optional)



x2  
MBZ003  
(optional)



x2  
MBZ004  
(optional)

## Integra System

---



x2  
Coax



x2  
Integra  
Connecting Cable



x2  
MBZ002  
(optional)



x2  
MBZ003  
(optional)



x2  
MBZ004  
(optional)

## MBZSUB82-1L

---



x2



x1  
MBZ-DSH-1



x1  
MBZ-DSH-2



x1  
MBZ-DSH-3

## MBZSUB82-2L

---



x2

# Component Woofer and Coax Adapter Assembly

## Assembly Overview

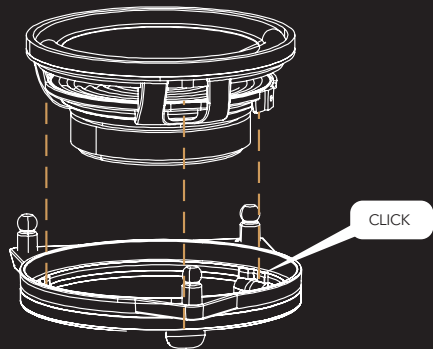

## Configuration A

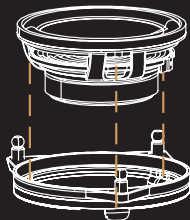

MBZ002

## Configuration B

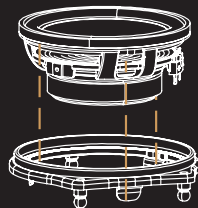

MBZ003

## Configuration C

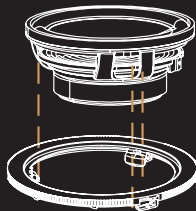

MBZ004



Scan for vehicle-specific  
compatibility information

# Speaker Connection

IR-MBZ42 / IR-MBZ42-CTR Component System

---

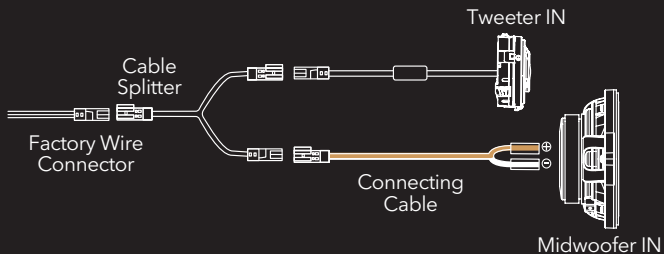

IR-MBZ4INT / IR-MBZ4INT-CTR Integra System

---

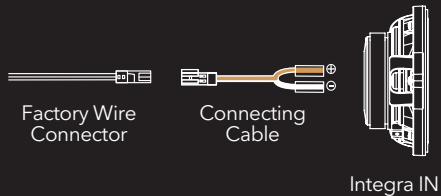

# Speaker Installation

4" Configuration A

---

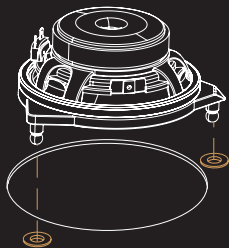

4" Configuration B

---

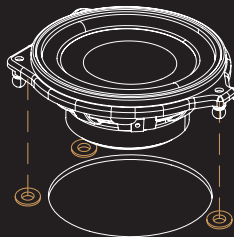

Tweeter

---

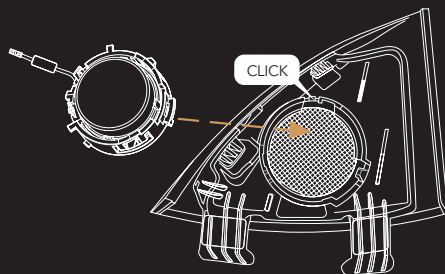

# Subwoofer Installation

MBZSUB82-1L

---

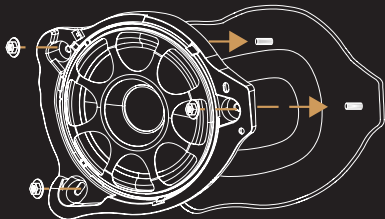

MBZSUB82-2L

---

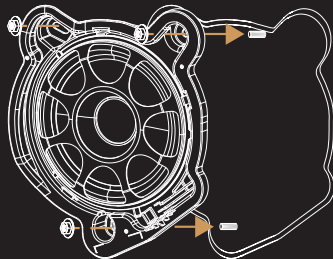

# Subwoofer Installation

Driver side

---

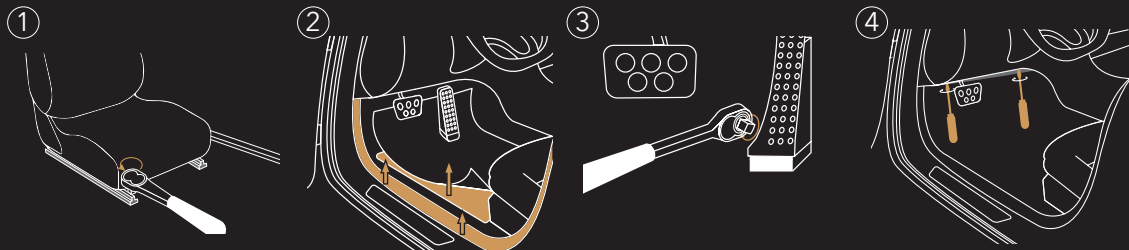

Passenger side

---

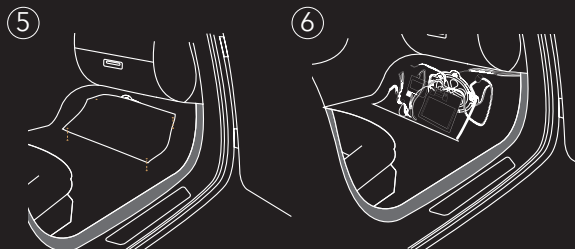



# Subwoofer Installation-MBZ-SUB82-IL

Single OEM Subwoofer to Dual Morel Subwoofer Wiring

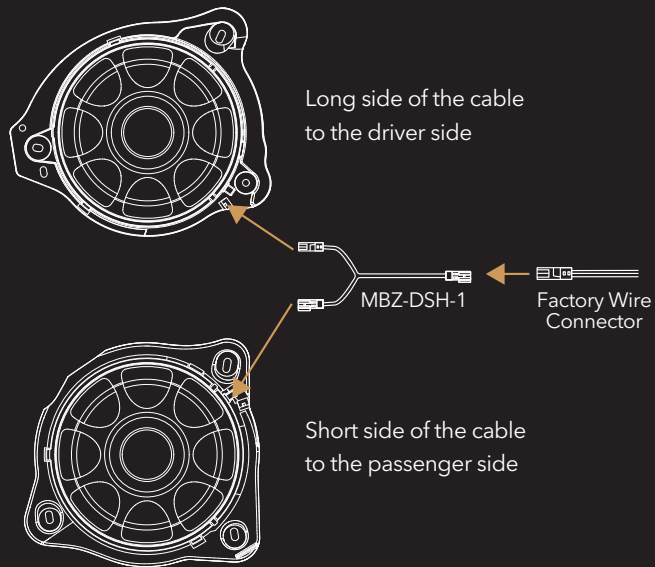

MBZ-DSH-1 connection to

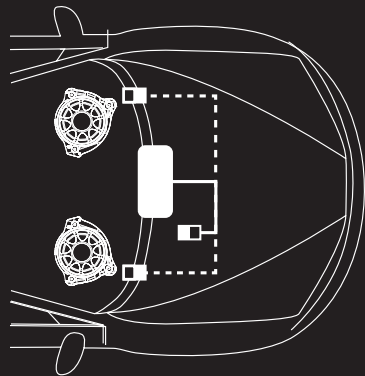

# Subwoofer Installation-MBZ-SUB82-IL

## Dual OEM Subwoofer to Dual Morel Subwoofer Wiring

---

For vehicles with two factory subwoofers, the OEM harness directly into our subwoofers

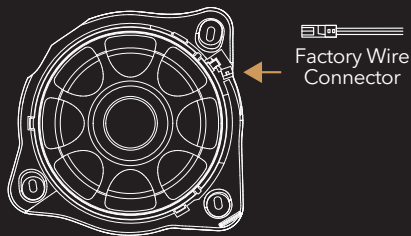
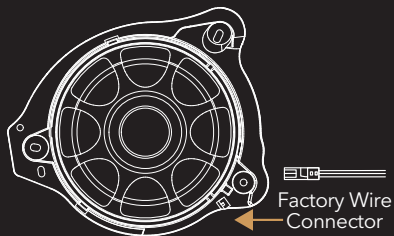

Use MBZ-DSH-2 and MBZ-DSH-3 to extend the OEM harness to fit to connector

---

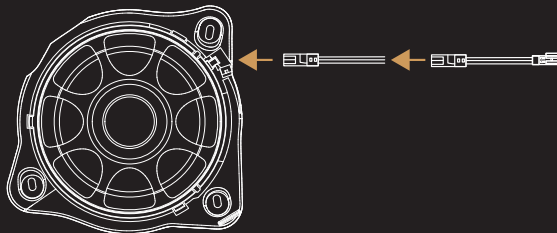
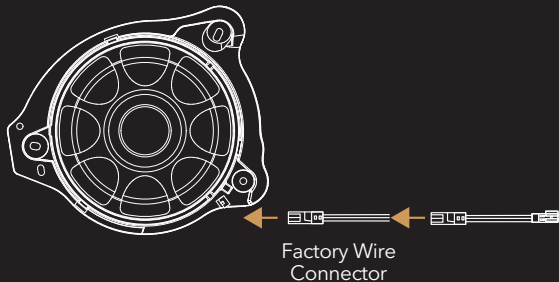

# Subwoofer Installation- MBZ-SUB82-1L

In case of using aftermarket amplifier

Use MBZ-DSH-2 or MBZ-DSH-3 harness

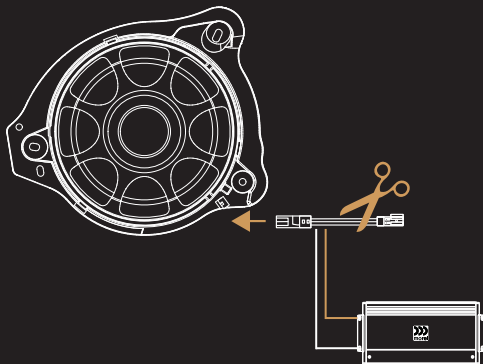
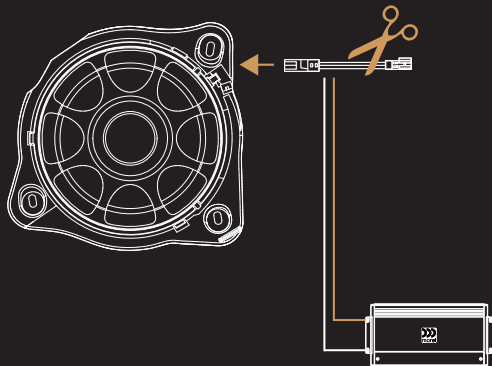

# Specifications

SYSTEM	IR-MBZ42 / IR-MBZ42-CTR	IR-MBZ4INT / IR-MBZ4INT-CTR	MBZSUB82-1L / MBZSUB82-2L
Nominal Impedance (ohm)	4	4	2
Power Handling Wrms	100	80	150
Max. Trans. Pwr Handling Wrms	300	250	500
Sensitivity (2.83 V/1M) dB	92	90	85
Frequency response Hz	50-25000	80-20000	20-600
Magnet System	Neodymium	Neodymium	Neodymium
Cone Material	W:DPC / T:Acuflex Soft dome	W:Composite cellular fiber / T:Acuflex Soft dome	Carbon

CROSSOVERS	TWEETER
Crossover Point	2700Hz/12dB (highpass)

\* Morel operates a policy of continuous products design improvement, consequently specifications are subject to alteration without prior notice



Morel, Ness Ziona, 70400 Israel.  
Tel: +972-8-9301161  
Fax: +972-8-9301312  
E-mail: [info@morelhifi.com](mailto:info@morelhifi.com)

Morel America, Chandler, AZ, USA  
Toll free number: 1-877-667-3511  
Fax: 1-718-721-1560  
E-mail: [info@morelamerica.com](mailto:info@morelamerica.com)

[www.morelhifi.com](http://www.morelhifi.com)



Scan for vehicle-specific  
compatibility information