



**Integration
Performance
Installation Guide**

BMW

IP-BMW42, IP-BMW42-CTR,
IP-BMW4C, IP-BMW4C-CTR
IP-BMW-SUB82

Dear Customer,

Thank you for choosing Morel for your car audio speaker solution.

Morel prides itself on engineering and producing the best high-fidelity speaker systems.

We hope you enjoy your Integration Performance speakers for years to come.

If you have any questions, please contact your Morel dealer or Morel support at:

www.morelhifi.com

Components

Component System



x2



x2
Connecting Cable



x2
Cable Splitter

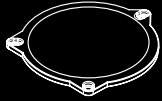

x2
Gasket



x2
Adapter 1



x2
Adapter 2

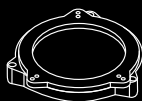

x2
Adapter 3



x2

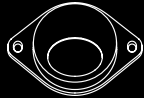

x2
Mounting bracket



x2
Tweeter crossover

Coax System



x2



x2
Connecting Cable

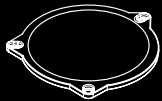

x2
Gasket



x2
Adapter 1



x2
Adapter 2



x2
Adapter 3

Subwoofer

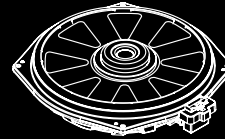

x1

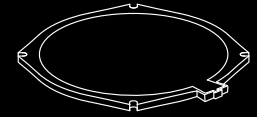

x1
Gasket

Installation tools

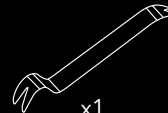

x1

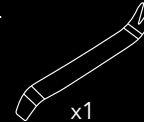

x1



x1



x1

Component Woofer and Coax Adapter Assembly

Assembly Overview

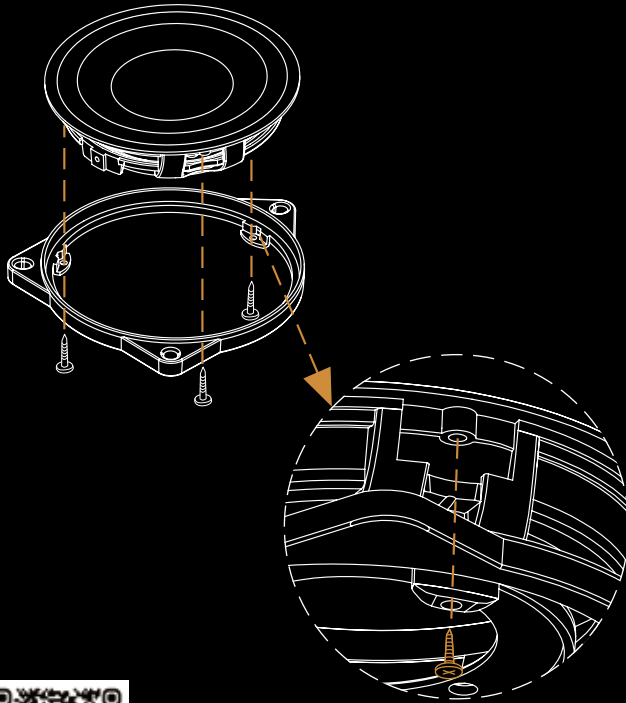

Scan for vehicle-specific compatibility information

Configuration A

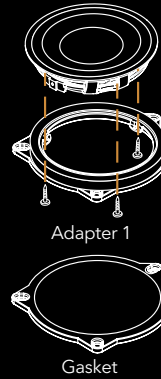

Configuration B

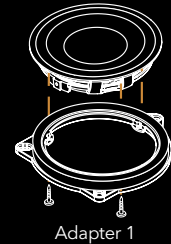

Configuration C

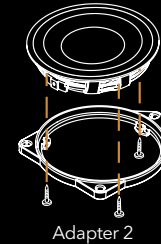

Configuration D

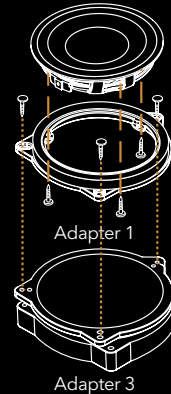

Speaker Connection

IP-BMW42 Component System

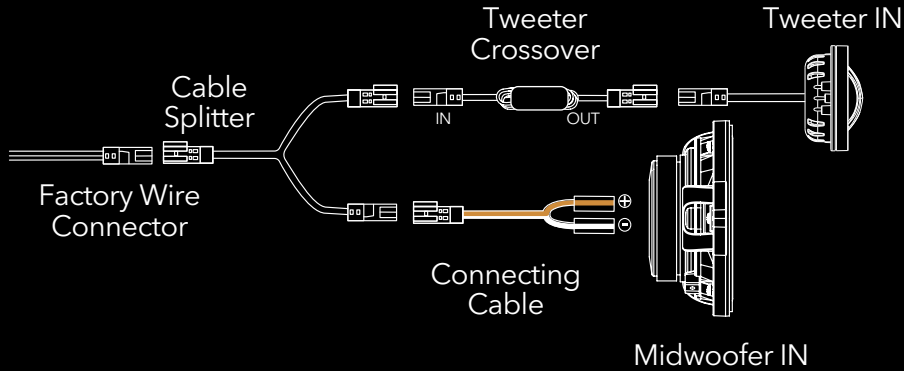

2 WAY System - Car integration set up wiring

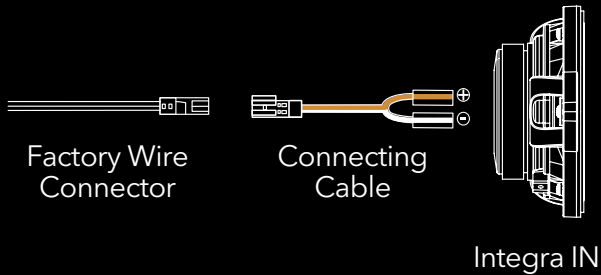

Woofers and Tweeter Installation

4" Trim Installation

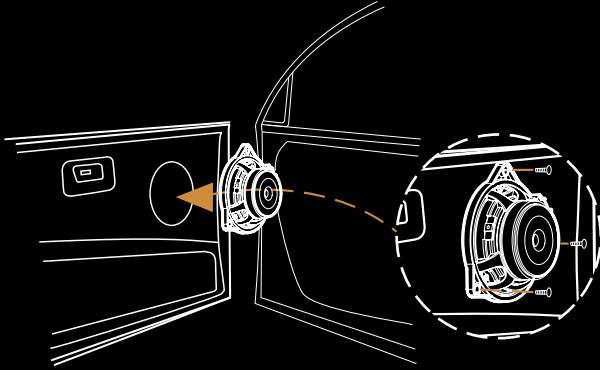

4" Door Installation

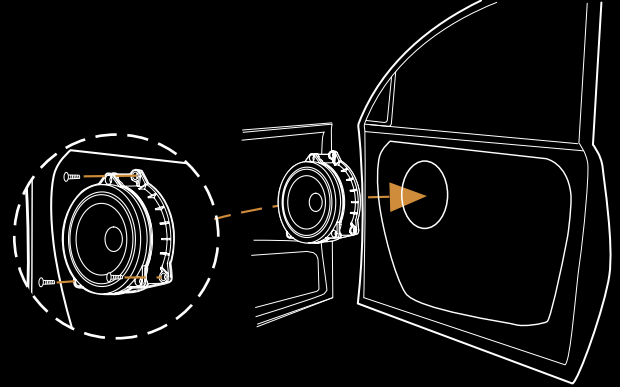

4" Center Deck Installation

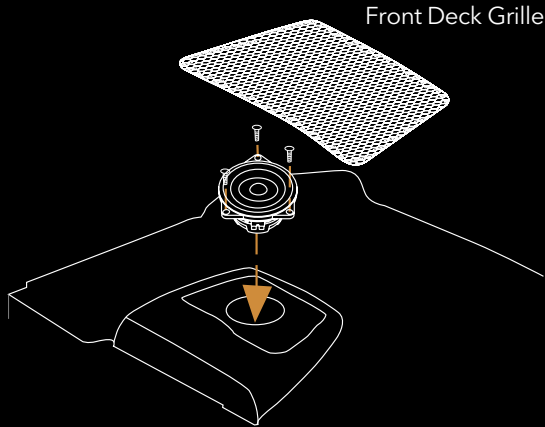

Tweeter Center / Rear Deck Installation

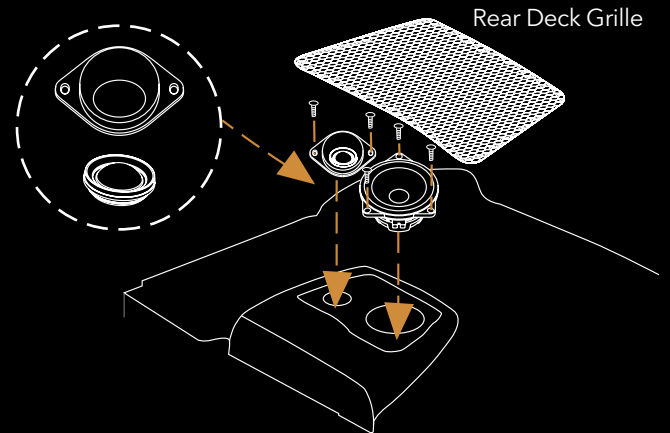

Woofers, Tweeter and Subwoofer Installation

Tweeter - Front Installation

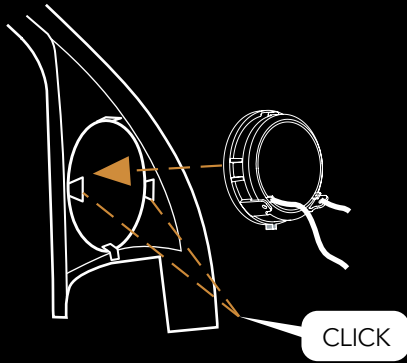

Subwoofer - Under Seat Installation

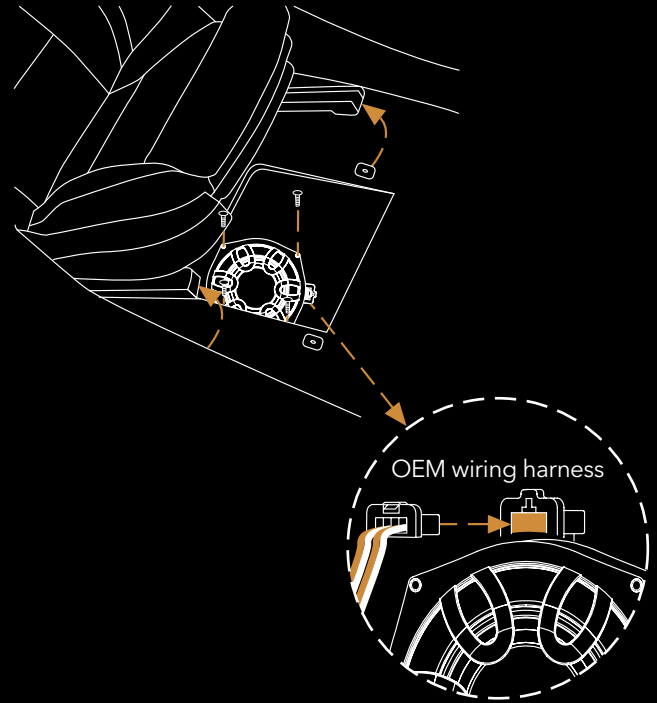

Specifications

WOOFERS	IP-BMW42	IP-BMW4C	IP-BMWSUB82
Nominal Impedance (ohm)	4	4	2
Power Handling Wrms	50	40	180
Max. Trans. Pwr Handling Wrms	120	120	500
Sensitivity (2.83 V/1M) dB	89	89	84
Frequency response Hz	80-20000	80-5000	20-1000
Resonant Freq. Fs Hz	110	110	30
Voice Coil Diameter mm (inch)	25 (1)	25 (1)	54 (2.1)
DC Resistance (ohm)	3.65	3.65	2.2
Magnet System	Hybrid Neodymium + Ferrite	Hybrid Neodymium + Ferrite	Neodymium
HE-Magnetic Gap Height mm (inch)			5 (0.20)
B-Flux Density (T)	0.94	0.66	0.75
BL Product/BXL	3	3.15	5.4
Suspension Compliance CMS - mm/N	0.37	0.37	0.46
Electrical Q Factor QES	1.47	1.32	0.83
QTS	0.9	0.9	0.57
QMS	3.27	3.4	1.84
Mech. Resistance RMS- N * S / M	1.11	1.06	6.1
Moving Mass MMS - gr/ounce	4.92(0.17)	4.84(0.17)	60 (2.11)
Equiv. Can Air Load VAS - L (cu.ft ³)	1.47(0.05)	1.19 (0.04)	42 (1.48)
Effective Piston Area SD sq.cm (sq.inch)	53(20.8)	48 (18.9)	254(100)
Cone Material	pp	pp	paper composite
Unit Diameter mm(inch)	96.7 (3.8)	96.7 (3.8)	8" BMW FIT
Mounting Depth mm (inch)	36.7 (1.44)	36.7 (1.44)	43.5 (1.71)
Mounting Cutout	92 (3.6)	92 (3.6)	192 (7.55)
Net Weight Kg (lb)	0.35 (0.77)	0.37 (0.81)	1.12 (247)

* Morel operates a policy of continuous products design improvement, consequently specifications are subject to alteration without prior notice

TWEETERS	IP-BMW42	IP-BMW4C
Nominal Impedance (ohm)	4	4
Power Handling Wrms	90	60
Max. Trans. Pwr Handling Wrms (10ms)	180	120
Sensitivity (2.83 V/1M) dB	90.5dB	86dB
Frequency Response Hz	1800-22000	2200-20000
Resonant Freq. Fs Hz	1000	1400
Voice Coil Diameter mm (inch)	28 (1.1)	19 (1)
Voice Coil Wire	Copper	Copper
Magnet System	Neodymium	Neodymium
Mounting Depth mm (inch)	20 (0.8)	

CROSSOVERS	IP-BMW42 Tweeter
Crossover Point	2700Hz/12dB



Morel, Ness Ziona, 70400 Israel.
Tel: +972-8-9301161
Fax: +972-8-9301312
E-mail: info@morelhifi.com

Morel America, Chandler, AZ, USA
Toll free number: 1-877-667-3511
Fax: 1-718-721-1560
E-mail: info@morelamerica.com

www.morelhifi.com



Scan for vehicle-specific compatibility information