

PRIMO SUBWOOFER SERIES

OWNERS MANUAL

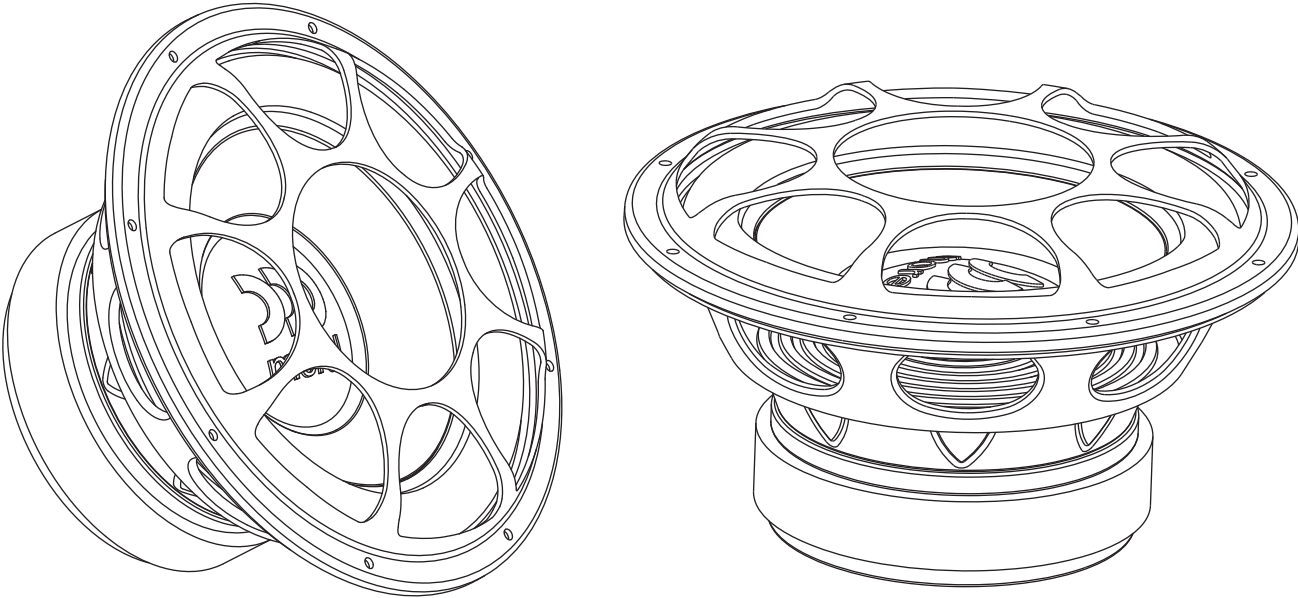

Introduction

Dear customer,

Thank you for choosing Morel's Primo subwoofer to satisfy your demanding car audio standards.

Morel strongly recommends installation by an Authorized Morel Dealer. Deriving the maximum from your Primo subwoofer requires knowledge of car audio acoustics and cabinet construction.

Choosing the correct enclosure

Primo subwoofers are designed to work optimally in both ported and sealed enclosures; however, these enclosure types produce a slightly different sound result.

The general guideline is that usually, the larger the enclosure is, the low bass frequency extension will be better, but it will have less bass control and definition.

On the contrary, as the enclosure volume gets smaller the bass reproduction gets faster and tighter but the low bass frequency response diminishes.

For those seeking optimal sound quality results, Morel suggests the use of a sealed enclosure; and if SPL is your preference, it is recommended to use a ported enclosure. The table below specifies the required volume range needed for the Primo Subwoofer series to produce the best results in both sealed and ported enclosures.

Ported (Bass reflex) enclosures

Ported enclosures utilize a circular or rectangular tube or vent to tune the enclosure. The port allows the back-wave produced by woofer to couple with its front wave, thereby reinforcing the bass output. A properly tuned ported enclosure provides an extended bass shelf, increasing low frequency output over a similarly sized sealed enclosure. In addition, a properly ported enclosure offers better power handling, efficiency, control and faster bass reproduction above the enclosure tuning frequency than that of a sealed enclosure.

Sealed enclosures

By nature of its design, a sealed enclosure is not affected by air pressure changes inside the enclosure due to cone movement. As a result, acoustic suspension and cone movement linearity are vastly improved, resulting in lower distortion and high power handling over its frequency range. The drawbacks of a sealed enclosure are inferior efficiency and reduced transient response at lower frequencies. However, a properly designed sealed enclosure will have a much flatter and controlled low frequency roll-off than a ported enclosure. In conclusion, sealed enclosures provide powerful bass reproduction, flat response and excellent dynamics with extremely low distortion.

Morel's recommended enclosure volumes for ported and sealed enclosures

	PRIMO 8	PRIMO 10	PRIMO 12
Ported Enclosure	15.5-31 Lit (0.55-1.1 cu.ft) Optimal performance at 20 Lit (0.71 cu.ft)	22-41 lit (0.8-1.45 cu.ft) Optimal performance at 31 Lit (1.1 cu.ft)	42-71 Lit (01.5-2.5 cu.ft) Optimal performance at 57 lit (2.0 cu.ft)
Sealed enclosure	12-22.5 lit (0.42-0.8 cu.ft) Optimal performance at 10 Lit (0.61 cu.ft)	20-34 lit (0.71-1.2 cu.ft) Optimal performance at 28 Lit (1.0 cu.ft)	27-52.5 Lit (0.095-1.85 cu.ft) Optimal performance at 38 Lit (1.35 cu.ft)

Primo ported and sealed enclosures

The following graphs simulate the Primo subwoofers optimal performance in ported and sealed enclosures. These guidelines will enable you to choose the best option suited for you. Please note: the recommended enclosure sizes specified include driver displacement.

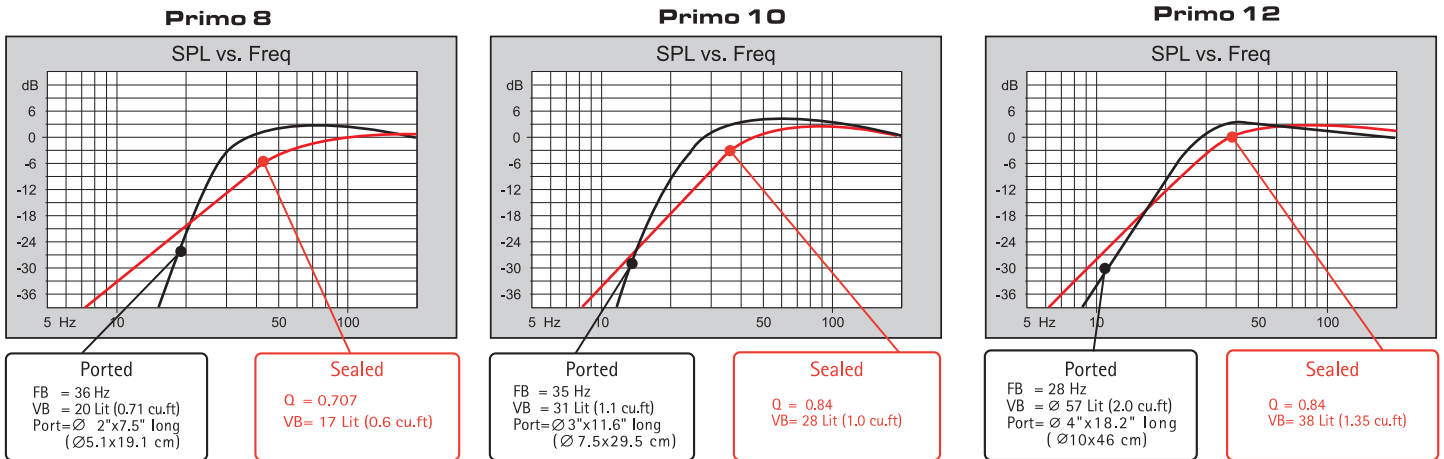

Connecting the Primo subwoofer

The Primo subwoofers may be connected to your amplifier in a variety of configurations, as suggested below.

Series connection (1-3 woofers)

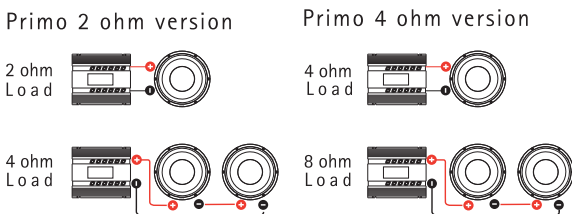

Parallel connection (2-4 woofers)

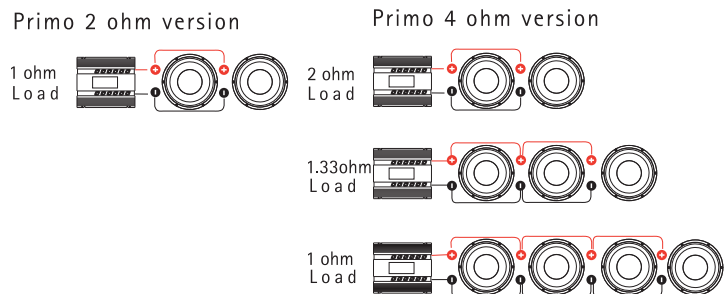

Tuning recommendation

Once the proper enclosure has been constructed, please follow these tips to optimize the performance of your new Primo subwoofer. It is always suggested to consult your Authorized Morel Dealer for more specific guidance, if necessary.

1. Set your gain level control to ensure stable amplifier operation without distortion or saturation to prevent subwoofer damage.
2. Adjust the cut-off frequency according to the enclosure design and subwoofer specifications to ensure optimal performance.
3. Electronic acoustic corrective filters (e.g. equalizer) are not required, as long as the subwoofer enclosure is designed properly.
4. After listening to the subwoofer you may choose to invert the phase. Inverting the phase will affect the acoustic performance of the subwoofer. It is recommended to listen in both configurations in order to determine your preferred mode.
5. Before adjusting your sound system further, it is suggested to move the subwoofer enclosure to different locations in the car trunk. Placing the enclosure in different locations may provide the solution you seek.

Primo Specifications

General data		PRIMO 8	PRIMO 10	PRIMO 12
Overall Dimensions	D	∅ 223mm (8.77")	∅ 263 mm (10.53")	∅ 305 mm(12")
Power Handling RMS	P	250 W	300 W	350 W
Transient power 10ms		500 W	600 W	700 W
Sensitivity 2.83Vrms/1M		89 dB	90 dB	91 dB
Frequency Response		25-900 Hz	22-900 Hz	20-900 Hz
Cone Material		Laminated paper	Laminated paper	Laminated paper
Net Weight		3.86 KG (8.5 lbs)	4.56Kg (10.05 lb)	4.7Kg.(10.36 lb)
Driver displacement		2.0 Lit (0.07cu.ft)	2.34 Lit (0.08 cu.ft)	2.6 Lit (0.09 cu.ft)
Voice Coil and Magnet Parameters				
Voice Coil Diameter		51 mm (2")	51 mm (2")	51 mm (2")
Voice Coil Height		24mm (0.94")	24mm (0.94")	24mm (0.94")
Voice Coil Former		Aluminum	Aluminum	Aluminum
Voice coil wire		Copper	Copper	Copper
Number of layers		2	2	2
Max. Linear excursion	X	± 8 mm (0.3") (Each way)	± 8 mm (0.3") (Each way)	± 8 mm (0.3") (Each way)
Magnet system type		High grade ferrite	High grade ferrite	High grade ferrite
HE-Magnetic gap height	HE	8mm (0.3")	8mm (0.3")	8mm (0.3")
Electrical Data				
Nominal Impedance	Z	4.0 Ohm	4.0 Ohm	4.0 Ohm
DC Resistance	RE	3.0 Ohm	3.0 Ohm	3.0 Ohm
T-S Parameters				
Suspension Compliance	CMS	0.19	0.27	0.28
Mechanical Q Factor	QMS	4	3.1	3.1
Electrical Q Factor	QES	0.70	0.68	0.56
Total Q Factor	QTS	0.60	0.56	0.47
Mechanical Resistance	RMS	4.6	5	6
Moving Mass	MMS	65 gr.	70 gr.	111 gr.
Resonant Frequency	FS	43 Hz	35 Hz	28 Hz
Eq. Cas Air Load (liters)	VAS	13.5 Lit (0.47 cu.ft)	38 Lit (1.34 cu.ft)	85 Lit (2.96 cu.ft)
Effective Piston Area	SD	219cm ²	320cm ²	434cm ²

Overall Dimensions

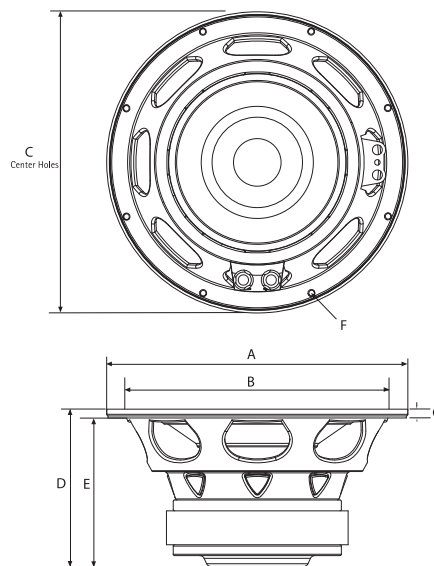

	PRIMO 8	PRIMO 10	PRIMO 12
A	∅ 8.77" (223mm)	∅ 10.53" (263mm)	∅ 12" (306mm)
B	∅ 7.83" (199mm)	∅ 9.17" (233mm)	∅ 10.7" (272mm)
C	∅ 8.34" (212mm)	∅ 9.88" (251mm)	∅ 11.45" (291mm)
D	4.56" (116mm)	5.11" (130mm)	5.62" (143mm)
E	4.33" (110mm)	4.88" (124mm)	5.35" (136mm)
F	∅ 0.196" (5mm)	∅ 0.196" (5mm)	∅ 0.196" (5mm)
G	∅ 0.196" (5mm)	∅ 0.196" (5mm)	∅ 0.255" (6.5mm)

Morel operates a policy of continuous product design improvement, consequently specifications are subject to alteration without prior notice.



Morel Ltd.
Tel: +972-8-9301161
Fax: +972-8-9301312
E-mail: info@morel.co.il
www.morelhifi.com

Morel America
Tel: 1-877-morel -11
Fax: 1-718-721-1560
E-mail: info@morelamerica.com

Warning

We care about your hearing!!! Morel's Primo series is capable of producing sound levels that can permanently damage your hearing! Turning up a system to a level that has audible distortion is more damaging to your ears that listening to an undistorted system at the same volume level. Please use common sense and precaution when using your sound system.